

# Maximizing the Number of Electric Matches That Can Be Fired in a Single Circuit

Michael A. Tockstein

Pyrotechnic Innovations, Wilmington, CA 90744 USA  
www.pyroinnovations.com

## ABSTRACT

*For a given electric match resistance and wire gauge, the number of electric matches that one can fire in a single circuit, using a standard DC firing system, depends on the arrangement in which the electric matches are wired (series, parallel or series-parallel). The number of electric matches fired from a single cue can be maximized by utilizing series-parallel circuits. This is demonstrated using graphs of the amount of current that is sent through each electric match in various series and parallel combinations. This data allows one to determine the maximum number of electric matches that can be successfully fired in a single circuit.*

**Keywords:** electric match, all fire current, cue, electrical firing, resistance

## Introduction

During a typical fireworks show or high power rocket launch using a low voltage DC firing system, an operator will often have multiple electric matches wired to a single cue to cause the simultaneous functioning of multiple effects or the ignition of a cluster of individual rocket engines. Thus it is reasonable to pose the question, how many electric matches can be reliably fired from one cue? Using the data in this article, the author demonstrates that the greatest number of electric matches can be fired on a single cue is when using a series-parallel combination, rather than using either a series or parallel circuit. The number of electric matches that can be fired in this way depends on the resistance of the electric matches, the wire gauge being used, the voltage and internal resistance of the firing system, the amount of current required to confidently fire each electric match, and details of

the series-parallel circuit (i.e., the number of electric matches in each parallel branch and the number of branches in series). This investigation uses standard circuit analysis techniques to determine how much current will flow through each electric match under the various scenarios being considered.

## Electric Matches

Only the two most commonly used electric match brands will be specifically considered in this article; however, similar methods of analysis could be applied to any type of electric match. Those two brands are Daveyfire and OXRAL. The properties of these electric matches are summarized in Table 1.

## Calculation Method for the Current Per Electric Match

The current that passes through each electric match during firing is dependent on its resistance and the voltage applied to it. This relationship is expressed as Ohm's Law.<sup>[4]</sup> However, for the purposes of the article, first it must be accepted that an electric match can be modeled by a simple resistance ( $R_{em}$ ), which is the electric match resistance given in the manufacturers' data sheets.

*Ohm's law:* The current ( $I$ ) in amperes through any portion of an electric circuit is equal to the drop in electric potential ( $E$ ) in volts across that portion of the circuit, divided by the resistance ( $R$ ) on ohms of that portion of the circuit, as shown in equation 1.

$$I = \frac{E}{R} \quad (1)$$

**Table 1. Electric Match Specifications.**<sup>[1-3]</sup>

Match Type	Resistance ( $\Omega$ ) <sup>[a]</sup>	All Fire Current (A) <sup>[b]</sup>	Wire Color	Series Firing Current (A) <sup>[c]</sup>
Daveyfire N28F	1.6 ± 0.3	1.00	Black	n/a
Daveyfire N28B	1.6 ± 0.3	0.37	White	n/a
Daveyfire N28BR	1.6 ± 0.3	0.37	Orange	n/a
OXRAL	2	0.5	Blue/Red	0.8

- a) *Electric match resistance*: Resistance (in ohms,  $\Omega$ ) of the electric match head (i.e., without considering the attached leg wires or contact resistance when being wired into a circuit).
- b) *All fire current*: The minimum current (in amperes, A) at or above which all electric matches should fire. For OXRAL electric matches, this current needs to be applied for a minimum of 0.05 seconds.<sup>[3]</sup> Daveyfire electric matches will typically fire in 0.002 seconds with one ampere of current flowing through them.<sup>[2]</sup>
- c) *Series firing current*: The manufacturer recommended firing current for multiple electric matches wired in series.

Ohm's law can only be used when the circuit is represented as a single equivalent resistance. If multiple resistances are placed in series, the summing of their individual resistances is all that is needed to obtain the total series resistance, as shown in equation 2.

$$R_T = \sum_{i=1}^n R_i = R_1 + R_2 + \dots + R_n \quad (2)$$

where  $n$  is the number of electric matches in series,  $R_T$  is the total equivalent resistance ( $\Omega$ ), and  $R_1, R_2, \dots, R_n$  is the resistance of each electric match. When all resistances in series have the same value,  $R$ , this reduces to

$$R_T = n \cdot R \quad (3)$$

Following is a discussion leading to calculation for the maximum number of electric matches that can be fired in series. Assume that the electric match has 2 ohms of resistance (match head plus leg wire resistance) and that the recommended electric match firing current is 1 ampere. Assume further that the firing system has an internal resistance of 4 ohms and uses a 24-volt power source. For all examples and graphs in this article, the internal firing system resistance includes the resistance from a 100-foot firing cable, 100 feet of returning ground wire, internal battery resistance, and circuit contact resistances. Keep in mind, that the resistance of the firing cables and ground wire is dependent upon the

gauge of the wire. For this reason, a table of wire resistance for various gauge wire is presented in Table 2. The resistance values are given for a complete round trip circuit (i.e., ohms/100 feet corresponds to 200 feet of wire). If necessary, the internal firing system resistance can be estimated by measuring the current supplied by the firing system when applied to a known small resistance and using Ohm's Law.

**Table 2. Table of Wire Resistances.**<sup>[5]</sup>

AWG (Gauge)	Feet/Ohm	Ohms/100 ft
10	490.2	.204
12	308.7	.324
14	193.8	.516
16	122.3	.818
18	76.8	1.30
20	48.1	2.08
22	30.3	3.30
24	19.1	5.24
26	12.0	8.32
28	7.55	13.2

Ohm's law can be used to find the maximum allowable resistance of a firing circuit. For a 24-volt firing system that provides one ampere firing current, the maximum circuit resistance that can be accommodated is

$$R_T = \frac{E}{I} = \frac{24 \text{ v}}{1.0 \text{ A}} = 24 \Omega \quad (4)$$

Remembering that the firing system's assumed internal resistance is 4 ohms, this must be subtracted from the total resistance,  $R_T$ , to obtain the total amount of resistance that the electric matches can provide,  $R_{TOTematches}$ .

$$\begin{aligned} R_{TOTematches} &= R_T - R_{\text{internal}} \\ &= 24 \Omega - 4 \Omega = 20 \Omega \end{aligned} \quad (5)$$

Simply divide the result given in equation 5 by the individual electric match resistance (assumed to be 2 ohms) to give the number of electric matches ( $n$ ) that can be fired in series with 1 ampere of current flowing through each electric match.

$$n = \frac{R_{TOTematches}}{R_{\text{ematch}}} = \frac{20 \Omega}{2 \Omega} = 10 \text{ e-matches} \quad (6)$$

From equation 6, it can be concluded that 10 electric matches can be fired in series (given that they require 1 ampere of current to flow through them, and that they each have a resistance of 2 ohms).

The calculations become a little more difficult when multiple electric matches are wired in parallel. In this case, the simple addition of the resistances will not yield the correct result. When electric matches are wired in parallel, equation 7 must be utilized to find the equivalent resistance. This equation is shown below

$$\frac{1}{R_T} = \sum_{i=1}^n \frac{1}{R_i} = \frac{1}{R_1} + \frac{1}{R_2} + \frac{1}{R_3} + \dots + \frac{1}{R_n} \quad (7)$$

where  $R_T$  equals the total equivalent resistance seen by the voltage source, and  $R_1, R_2, \dots, R_n$  are the resistances of each electric match. When all of the resistances in parallel are equal, equation 7 reduces to

$$R_T = \frac{R}{n} \quad (8)$$

where  $n$  is the number of resistances in parallel.

Based on equation 8, the total resistance of the circuit is greatly reduced when the electric matches are placed in parallel (as compared with the same number in series). Advantage can be taken of this result by remembering that Ohm's

law states that the amount of current that the voltage source supplies is inversely proportional to the amount of resistance in the circuit.

Once the equivalent resistance is calculated for a parallel, Ohm's law can be used to determine the total amount of current ( $I_T$ ) that will flow from the voltage source. It must be kept in mind that each electric match in parallel will only have a fraction of the total electric current sent through the circuit. Once this current has been determined, it becomes necessary to divide it by the number of electric matches that are in parallel to yield the current per electric match, see equation 9:

$$\frac{\text{Current}}{\text{Electric match}} = \frac{I_T}{n} \text{ (amps)} \quad (9)$$

where  $n$  is the number of electric matches in parallel. Equation 9 allows the determination of whether the manufacturer's recommended firing current is being sent through each electric match in the circuit.

If there were no internal firing system resistance limiting the amount of current that will flow through one's electric matches, then a parallel wiring scheme would be ideal; however, this is not the case. With this in mind, it can not be assumed that wiring great multiples of electric matches in parallel will lower the resistance to the point of allowing an infinite number of matches to be fired in parallel. For example, using the same assumptions as in the series calculation above, the maximum number of electric matches (with the resistance of 2 ohms that can be fired in a parallel combination using a 24-volt firing system and still have at least one ampere of current flowing through each electric match) is five electric matches. This is only half the total number of matches that could be fired using the series circuit.

Using the above information about separate series and parallel calculations, the two types of circuits can now be combined to maximize the number of electric matches that can be fired on one cue of the firing system.

## Series-Parallel Combinations

As discussed above, each set of parallel electric matches is seen by the power source as its equivalent resistances given by equation 8. Placing a number of these parallel sets of electric matches in series with each other, the total circuit resistance that is seen by the source is given by equation 3. The result is that the total resistance is reduced as compared to the same given number of electric matches had they all been wired in series. Performing each series-parallel combination calculation by hand would be tedious, so a computer algorithm was written applying the above mathematical equations. The computer program presents the data graphically for an easy comparison of the various series-parallel combinations. The various lines on the graphs in Figures 2 to 4 represent a different number of electric matches in parallel. The horizontal axis of each graph shows the number of sets of these parallel electric matches that are wired in series. The vertical axis shows the calculated electric current that each electric match will receive for the given series-parallel combination. If clarification is needed on how to wire such a series-parallel combination, an example is shown in Figure 1. (Note that this might be described as a series of parallel groups of electric matches.)

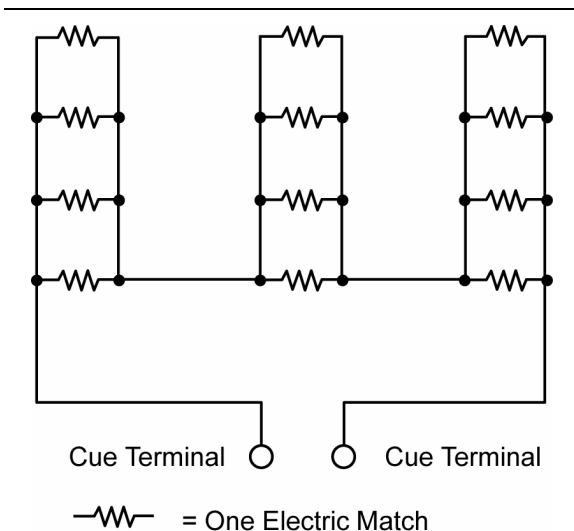

Figure 1. Electric match circuit (a series of 3 sets of 4 electric matches in parallel).

## Theoretical Results

From a batch of Daveyfire electric matches, 10 were drawn at random, and their individual resistance was measured. The measured resistance included the 3-meter lead wire that came attached to the electric match head. The maximum measured resistance was 3.4 ohms. Figure 2 is a graph of results using 3.4 ohms as the electric match resistance. Figure 3 is a graph of results using the typical value of the group of measured Daveyfire electric matches, which was 2.6 ohms. Figure 4 is a graph of results using the resistance of 2 ohms, which is given by the manufacturer's data sheet for most other types of electric matches, which includes OXRAL. Each graph also assumed 4 ohms of internal firing system resistance, which is typical of most fireworks firing systems. (Rocketry firing systems tend to have a much lower resistance, approximately 1 ohm, due to the close proximity of the power source to the electric matches i.e., there is almost no firing cable resistance).

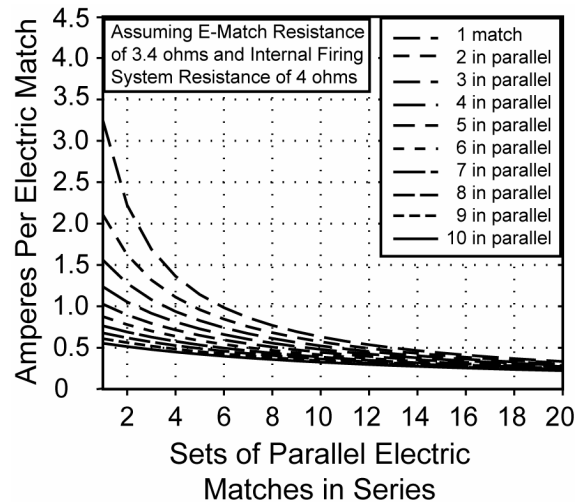

Figure 2. Graph using the maximum measured Daveyfire resistance of 3.4 ohms.

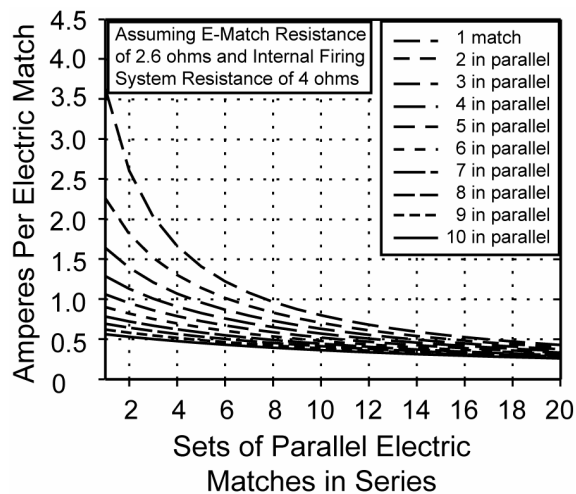

Figure 3. Graph using the typical measured Daveyfire resistance of 2.6 ohms.

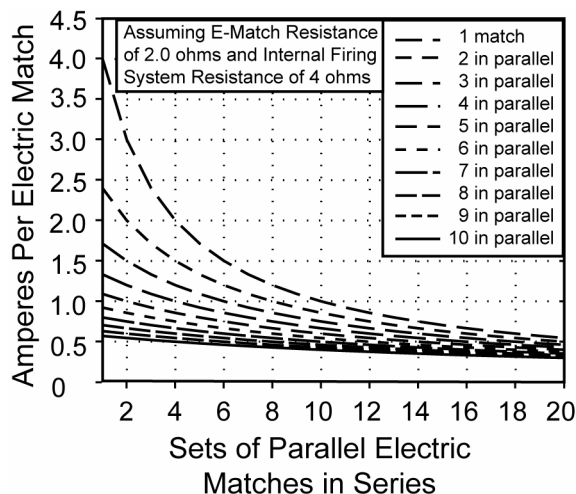

Figure 4. Graph using the resistance listed on the OXRAL electric match data sheet, 2 ohms.

For electric matches with resistances of 3.4, 2.6, and 2.0 ohms, the above graphs indicate that properly chosen series-parallel circuits will be capable of providing 1 ampere of firing current to 9, 12, and 16 electric matches, respectively.

## Experimental Results

To test the results provided in this article, sets of 50 Daveyfire electric matches were test fired using a 24-volt power source with 4.0 ohms of internal resistance. The electric matches used in the tests each had a measured resistance of  $2.6 \pm 1$  ohms. In the first test the electric matches were wired in series. Using the equations given above, the electric current through each electric match should have been approximately 0.18 ampere. (This is less than the manufacturer's no-fire current.) In this test none of the electric matches fired. In the second test the electric matches were wired in parallel. Using the equations given above, the electric current through each electric match should have been approximately 0.12 ampere. In this test again none of the electric matches fired. In the third test a series of 5 sets of 10 electric matches in parallel were wired together. The all-fire current for Daveyfire electric matches is 0.37 amperes, and the graph in Figure 3 indicates that a current of 0.42 amperes will flow through each electric match in this configuration, such that each electric match should fire. In the test, all 50 of the electric matches fired. (All of the electric matches used in this test were donated by the *Friends of Amateur Rocketry, Inc.*<sup>[6]</sup>)

## Conclusion

Using the results of this study, the number of electric matches that can be fired with relative certainty can be determined. However, it is important to keep in mind that the data used for the graphs assumed a specific firing system resistance and a specific electric match resistance. It was also assumed that each electric match has the exact same resistance, which can vary slightly from match to match. Knowing this, the reader is cautioned to use this data in a manner that leaves room for these uncertainties. By only using series-parallel combinations that will yield a current of more than one ampere, one can be confident that all of the electric matches in the circuit will fire.

## References

- 1) Web site: [http://www.info-central.org/recovery\\_ematches.shtml](http://www.info-central.org/recovery_ematches.shtml)
  - 2) Web site:  
<http://www.vernk.com/Igniters.htm>
  - 3) Web site: [http://www.pyropak.com/oxral\\_electric\\_matches.shtml](http://www.pyropak.com/oxral_electric_matches.shtml).
  - 4) James W. Nilsson, *Electric Circuits*, Prentice-Hall, 2001.
  - 5) Web site:  
[http://www.epanorama.net/documents/wiring/wire\\_resistance.html](http://www.epanorama.net/documents/wiring/wire_resistance.html)
  - 6) Friends of Amateur Rocketry, Inc.  
<http://far.pyroinnovations.com>
- 

## Keywords and Authors Lists

Currently available on the JPyro web site [<http://www.jpyro.com>] is a downloadable PDF file that contains a listing of keywords, authors, and titles of articles that have appeared in the first 19 issues of the *Journal of Pyrotechnics*. This often comes in handy when you are trying to find an article that you know you've seen in a past issue, but you don't remember which one.

Also remember that all past issues of the Journal are still available, so if you find an article that you want from a past issue you have two options available. You can purchase the past issue from the JPyro web site, or you can request an individual article. The cost for emailing you a past article, in PDF format, is 50¢ per page with a minimum charge of \$5.00. If you email me a message at [bonnie@jpyro.com](mailto:bonnie@jpyro.com), I can let you know how many pages are in the article, so that you can figure what the cost would be.

If you have questions or comments about the keyword and author lists, please let us know. Full contact information is available on the back of the front cover.

Thank you for your continued support of the Journal.